

6 DEVELOPMENT AND ASSESSMENT OF POSSIBLE FUTURE MANAGEMENT OPTIONS / STRATEGIES

6.1 Formulation of Options / Strategies

Management options or strategies are the tools that will be used to try to achieve the management targets or objectives. Management options include a range of different types of activities, such as on-ground works, community education, planning and development controls, and future monitoring.

For each of the 18 management objectives (which are based on the specific issues as discussed in Section 4.4), a number of management strategies / options were formulated for addressing (at least in part) the objective.

A total of 34 different options were formulated, each with the primary aim of improving the future sustainability of Killick Creek. These options are presented below under the general headings of water quality, entrance management, sedimentation, ecology, and floodplain and agricultural management.

6.1.1 Options Addressing Water Quality Objectives (Objectives 1 – 4)

- WQ-1 Review and continue to implement the recommendations of the Crescent Head Stormwater Management Plan
- WQ-2 Ensure appropriate connections to sewer and rationalise stormwater discharges from the Caravan Park
- WQ-3 Install 'leaky pits' in the caravan park, with low flows infiltrating into the sand and only high flows directed into Killick Creek
- WQ-4 Upgrade the reticulated sewerage system to reduce the frequency of sewage overflows
- WQ-5 Encourage on-site stormwater management (eg rainwater tanks, absorption trenches, grass swales) through education and incentive schemes
- WQ-6 Public education regarding impacts of stormwater on the sensitive receiving waters and the recreational usability of the estuary, along with signage advising of the suitability of Killick Creek for primary recreation activities, especially during and after rain events, and when the entrance is closed
- WQ-7 Public education regarding collection of animal faeces from within the catchment
- WQ-8 Prohibit discharge of agricultural runoff and floodwaters unless the water quality meets given targets
- WQ-9 Immediately artificially open the entrance, if it closes during the main holiday period (October to April)

- WQ-10 Artificially open the creek entrance during non-holiday times (May to September) if water quality degrades to threshold levels
- WQ-11 Extend the existing Stormwater Management Plan (GHD, 2003) to undertake a detailed pollutant source inventory study of Crescent Head, involving extensive event-based monitoring of targeted contaminants throughout the Crescent Head stormwater system
- WQ-12 Continue to monitor for bacteria (eg enterococci) within primary swimming areas and correlate results against rainfall to provide a basis for informing the public regarding risks of illness
- WQ-13 Prepare and implement a comprehensive water quality monitoring program for Killick Creek, based on periodic (low flow) sampling, supplemented by episodic (high flow) sampling following major rainfall and agricultural drainage releases, and following red weed incursion into the estuary
- WQ-14 Prepare and adopt a DCP for all new urban development in Crescent Head village that requires new dwellings to adopt on-site management of stormwater and appropriate Water Sensitive Urban Design principles to minimise runoff and pollutant load exports to Killick Creek

6.1.2 Options Addressing Entrance Management Objectives (Objectives 5 – 6)

- EM-1 Critically assess the actual threat to the coastal dunes associated with natural meander of the entrance channel and other justifications for undertaking the works
- EM-2 Prepare and implement a formal Entrance Management Policy regarding on-going works within the entrance channel, such as artificial openings and meander corrections, which outlines the triggers for works, as well as an appropriate methodology that will minimise environmental impacts and maximise recreational opportunities
- EM-3 Install appropriate signage outlining the hazards associated with tidal currents through the entrance

6.1.3 Options Addressing Sedimentation Objectives (Objectives 7 – 9)

- Sed-1 Minimise floodwater flows into Killick Creek for a sufficient length of time to allow sediment to settle out in the agricultural drains
- Sed-2 Construct a block (weir) in the drains upstream of the floodgates to induce sedimentation in the agricultural drains
- Sed-3 Identify and remove / dredge sediment shoal in Killick Creek (including sections of the active marine delta), which inhibit the effectiveness of tidal flushing and drainage from agricultural lands

6.1.4 Options Addressing Ecology Objectives (Objectives 10 – 12)

Would largely be addressed through options already identified under other headings, but also:

- Ecol-1 Rezone the estuary and its surrounding habitats to 'Environmental Protection', reflecting its existing environmental values
- Ecol-2 Assess areas of coastal wetland to determine if any changes to existing gazetted SEPP-14 wetlands boundaries are warranted, and to map the presence of existing endangered ecological communities, such as saltmarsh, and protect through LEP revision.
- Ecol-3 Undertake riparian re-vegetation in sections of the estuary that have been denuded of foreshore vegetation
- Ecol-4 Undertake targeted rehabilitation of coastal wetlands through weed removal and planting or appropriate indigenous species
- Ecol-5 Undertake periodic flora and fauna surveys of the waterway and the foreshore areas to document community structure and utilisation by fauna.

6.1.5 Options Addressing Floodplain and Agricultural Management (Objectives 13 – 18)

- FM-1 Prepare and implement a formal floodgate management plan for the existing Killick Creek floodgates and the drop-boards
- FM-2 Upgrade / repair floodgates to ensure they operate effectively and as per requirements of the floodgate management plan
- FM-3 Carry out a hydrological model study of the Belmore Swamp area to assess the alternatives to using Killick Creek as a major drainage path
- FM-4 Conduct a detailed agricultural and economic assessment of land management practices in the upper Belmore Swamp area to justify the on-going use of the floodgates in their current or modified form, and to recommend appropriate landuse changes and agricultural practices to sustain an economically viable industry
- FM-5 Assess the likely impacts of sea level rise on the hydrology of Belmore Swamp and determine a timeframe over which the projected sea level rise will render the Swamp area unsuitable for agricultural pursuits
- FM-6 Continue trials of improved backswamp management with targeted education of agricultural landholders regarding appropriate ASS management
- FM-7 Restore entrance training wall to current engineering standards, including a consistent and larger rock size, a geotextile filter, and appropriate provision for stormwater outlets (new option included following public exhibition of draft EMP in February 2006).

6.1.6 Options Addressing Multiple Objectives

Multi-1 Carry out an environmental flows assessment of the estuary to determine an acceptable level of agricultural drainage into the estuary that maintains a healthy water quality, sediment and ecological environment.

Multi-2 Establish a number of local, community-based 'Estuary custodians' who can make regular (daily) observations of the estuary, and provide information back to Council and other appropriate authorities regarding adaptive management strategies, such as water quality monitoring, floodgate operation and entrance management. This role is an adaptation of the 'Riverkeeper' role used widely overseas as well as in some local estuaries, such as the Woronora and Lower Hawkesbury Rivers.

6.2 Assessment of Possible Options / Strategies

Even though each of the 34 possible management options would go some way towards achieving the goals and objectives of this Estuary Management Plan, the greatest benefits will be gained if the most effective options are implemented first. To determine which options are likely to be the most effective, a multi-criteria decision making process was adopted to compare and prioritise the 33 options initially formulated.

Preferred management options were determined by consideration of the following criteria:

1. Effectiveness of the options in addressing the specific management issues;
2. Acceptance of the options by the community and stakeholders;
3. Indicative costs of implementation;
4. The number and priority of objectives addressed by each individual management options;
5. Requirements for the prior completion of other management options;
6. Options should have a range of different implementation approaches;
7. Options should have a range of different implementation timeframes.

For criteria No. 6, 'different implementation approaches' include:

- Administration;
- Education;
- Investigation and Review;
- Planning and Controls;
- On-ground Works; and
- Monitoring.

For criteria No. 7, the different timeframes considered include:

- Immediately (next 6 – 12 months);
- Short term (1 – 3 years); and

- Medium term (3 – 5 years).

Much of the information used in the decision making process was obtained from the community and stakeholder groups via feedback from workshop discussions and one-on-one communications, particularly in regards to the first two criteria.

The final preferred order of implementation represents the most efficient and effective approach from an outcomes viewpoint, and as such, provides the most ‘bang for your buck’.

6.2.1 Results of Multi-Criteria Assessment

The results of the multi-criteria assessment are detailed in Appendix E, however, a summary of these results are outlined below. Figure 6-1 shows the relative scores representing the results of the multi-criteria assessment. These scores take into consideration the number of objectives addressed by each option, the relative importance (score) of each objective addressed (refer Section 5.7), the relative cost of implementation, and the relative effectiveness and acceptability of each option.

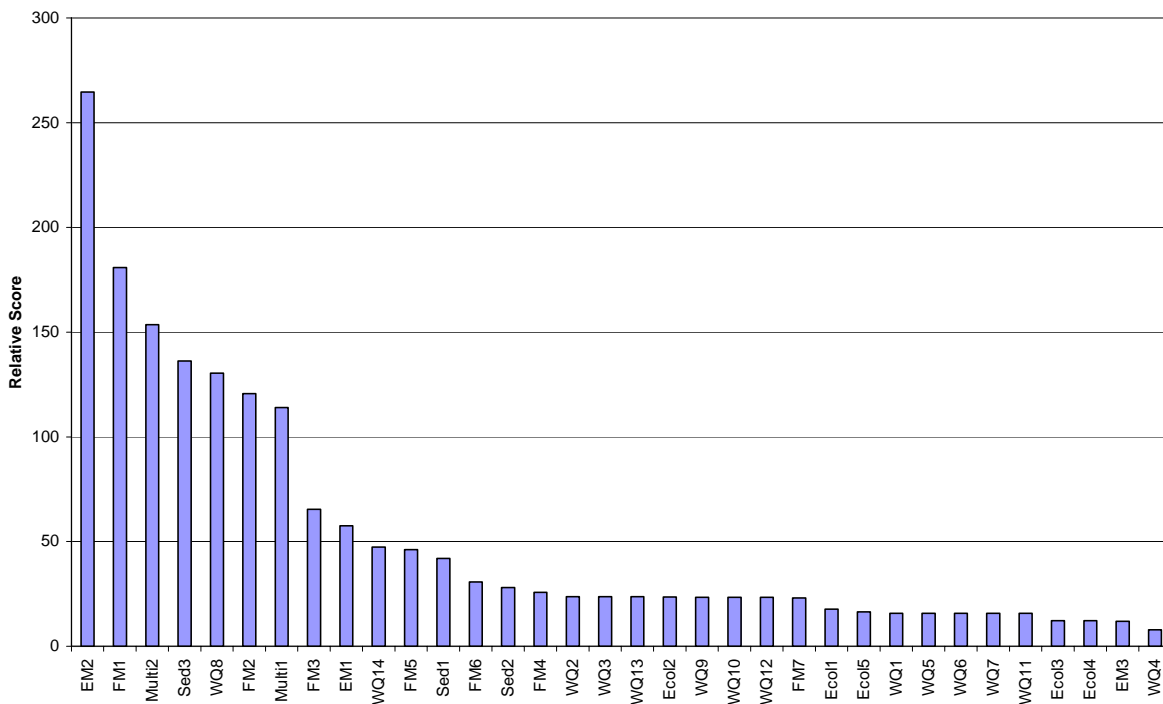

Figure 6-1 Relative Scores for Possible Management Options

A large number of possible options have an approximately equal relative assessment score (with values between 15 and 30, refer Figure 6-1). Although these options are not the highest ranking options, it is considered that the implementation of many of these would be of significant benefit to Killick Creek, particularly as they introduce a range of different management approaches and timeframes when compared to the highest scoring options, thus complying with Criteria 6 and 7, as discussed above.

6.2.2 Short-List of Preferred Management Options

Based on the results of the multi-criteria assessment, a short-list of management options has been developed. These short-listed options represent the options that scored the highest in the assessment as well as some options that provide diversity in terms of implementation approaches and timeframes. Also, some options have been consolidated to further reduce the number incorporated into the final Plan. For example, Options Sed-1 and WQ-8 have been consolidated in the Option FM-1, Options WQ-9 and WQ-10 have been consolidated into Option EM-2, Options WQ-2, WQ-6, WQ-7 and WQ-12 have been consolidated into Option WQ-1, and Option FM-5 has been incorporated with Option FM-4. The scope of the newly consolidated Options has duly been expanded to incorporate the scope of the previous Options that are not included specifically in the Plan.

Furthermore, the short-list of preferred management options incorporates feedback from Council, stakeholders and the general community following public exhibition of the draft Killick Creek Estuary Management Plan in February 2006. This feedback included the exclusion of Option Multi-2 from the short-list, and the inclusion of a new option (FM-7) that addresses the new Issue S (and Objective 18) relating to remediation of the currently dilapidated entrance training wall.

The short-listed options represent the best potential for meeting *all* objectives (ie at least one option is provided to address every management objective) and thus making significant improvements to the system, when implemented fully. These preferred management options are presented in Table 6.1.

Table 6.1 Short-List of Preferred Management Options

Option No.	Option description	Relative Score	Management Approach	Relative Timeframe
EM-2	Prepare a formal Entrance Management Policy	265	Planning	Immediate
FM-1	Prepare a formal Floodgate Management Policy	181	Planning	Immediate
Sed-3	Remove shoals that inhibit flood and tidal flows	136	On-ground wks	Short
FM-2	Upgrade floodgates to ensure they operate effectively	121	On-ground wks	Short
Multi-1	Carry out an environmental flows assessment	114	Further invest.	Medium
FM-3	Hydrological model study of the Belmore Swamp area	65	Further invest.	Medium
EM-1	Critically assess the actual threat to the coastal dunes	58	Further invest.	Immediate
WQ-14	Prepare a DCP for all new urban development	47	Planning	Short
FM-6	Targeted education of agricultural landholders	31	Education	Short
Sed-2	Construct a block in the drain u/s of the floodgates	28	On-ground wks	Medium
FM-4	Agricultural and economic assessment of land practices	26	Further invest.	Short
WQ-3	Install 'leaky pits' in the caravan park	24	On-ground wks	Immediate
WQ-13	Water quality monitoring program for Killick Creek	24	Monitoring	Short
Ecol-2	Assess wetlands and EEC areas and protect, as necess	24	Further invest.	Medium
WQ-12	Continue to monitor for bacteria (eg enterococci)	23	Monitoring	Immediate
FM-7	Restore entrance training wall to engineering standards	23	On-ground wks	Short
Ecol-1	Rezone the estuary to 'Environmental Protection'	18	Planning	Medium
Ecol-5	Flora / fauna surveys of the waterway and the foreshore	16	Monitoring	Long

Option No.	Option description	Relative Score	Management Approach	Relative Timeframe
WQ-1	Implement Crescent Hd Stormwater Management Plan	16	O-GW+ Educ.	Immediate
WQ-5	Encourage on-site stormwater management	16	Education	Medium
Ecol-3	Undertake riparian re-vegetation	12	On-ground wks	Short
EM-3	Install signage outlining the hazards of the entrance	12	On-ground wks	Immediate

A total of 22 options were short-listed from the initial list of 34. It is considered that 22 individual options / strategies would be a sensible number to aim for within the Estuary Management Plan given the realities of funding and resourcing difficulties within the State and Local Government authorities that will be responsible for implementation.

Of the 12 options not included specifically, eight have been incorporated into other options, and one was rejected by Council (Multi-2) following public exhibition of the draft Plan. Only three options were not included in the Plan in any form. All options will be reconsidered as part of any future reviews of the Estuary Management Plan. Future reviews of the document will be very important to ensure that the Plan remains relevant, and is considerate of new technologies, approaches and methods for environmental management (i.e. achieves adaptive management).

An 'Options and Objectives matrix' is shown in Table 6.2. This matrix illustrates the connection between defined management objectives (refer Section 5) and the 22 short-listed options, as defined in Table 6.1. From Table 6.2 it can be seen that all objectives are addressed by at least one management option, while most objectives are addressed by multiple options (maximum of 8 options is respect of Objective No. 2). Option EM-2 addresses a total of ten (10) separate objectives, while Options Sed-3 and FM-1 address seven objectives each. Most options address two or more objectives.

Table 6.2 Short-listed Management Options and Objectives Matrix

Strategies	Management Objectives																		
	1	2	3	4	5	6	7	8	9	10	11	12	13	14	15	16	17	18	
WQ-1	✓	✓																	
WQ-3	✓	✓																	
WQ-5	✓	✓																	
WQ-12		✓																	
WQ-13	✓	✓																	
WQ-14	✓	✓																	
EM-1						✓				✓	✓								
EM-2		✓		✓	✓	✓	✓	✓		✓	✓	✓							✓
EM-3					✓														
Sed-2									✓		✓								
Sed-3		✓	✓			✓	✓		✓	✓									✓
Ecol-1										✓	✓								
Ecol-2										✓	✓								
Ecol-3											✓								

Strategies	Management Objectives																	
	1	2	3	4	5	6	7	8	9	10	11	12	13	14	15	16	17	18
Ecol-5											✓							
FM-1			✓						✓			✓	✓	✓	✓		✓	
FM-2			✓						✓				✓	✓	✓		✓	
FM-3															✓	✓	✓	
FM-4																✓		
FM-6															✓	✓		
FM-7						✓												✓
Multi-1			✓			✓			✓	✓			✓	✓				

6.2.3 Proposed Implementation Order

Given the results of the multi-criteria assessment, and input from the community and council following the public exhibition of the draft Estuary Management Plan, a final recommended order of implementation for the preferred management options has been developed. This order is listed in Table 6.3.

Table 6.3 Implementation Order for Preferred Management Options

<u>To be implemented immediately (within 6 – 12 months)</u>	<u>Rank</u>
EM-2: Prepare & implement an Entrance Management Policy ⁽¹⁾	1/22
FM-1: Prepare & implement a Floodgate Management Policy ⁽²⁾	2/22
EM-1: Critically assess the actual threat to the coastal dunes	3/22
WQ-3: Install 'leaky pits' in the caravan park	4/22
WQ-12: Continue to monitor for bacteria (eg enterococci)	5/22
WQ-1: Implement Crescent Head Stormwater Management Plan	6/22
EM-3: Install signage outlining the hazards of the entrance	7/22
<u>To be implemented in the short term (within 1 – 3 years)</u>	
Sed-3: Remove possible shoal in middle reaches of Killick Ck	8/22
FM-2: Upgrade floodgates to ensure they operate effectively	9/22
WQ-14: Prepare a DCP for all new urban development	10/22
FM-6: Continue targeted education of agricultural landholders	11/22
FM-4: Agricultural and economic assessment of land practices	12/22
WQ-13: Water quality monitoring program for Killick Creek	13/22
FM-7: Restore entrance rock training wall to engineering standard	14/22
Ecol-3: Undertake riparian re-vegetation	15/22
<u>To be implemented in the medium term (within 3 – 5 years)</u>	
Multi-1: Carry out an environmental flows assessment	16/22

FM-3: Hydrological model study of the Belmore Swamp area	17/22
Sed-2: Construct a block in the drain u/s of the floodgates	18/22
Ecol-2: Assess wetland and EEC areas and protect, as necessary	19/22
Ecol-1: Rezone the estuary to 'Environmental Protection'	20/22
Ecol-5: Flora / fauna surveys of the waterway and the foreshore	21/22
WQ-5: Encourage on-site stormwater management	22/22

(1) Interim protocols for the Entrance Management Policy have been prepared (refer Appendix A) outlining when, where and how to manage the Killick Creek entrance in the future.

(2) Interim protocols for the Floodgate Management Policy have been prepared (refer Appendix B) outlining when and how to manage the Killick Creek floodgates in the future.

6.3 Descriptions of Preferred Options / Strategies

The following sections present detailed descriptions of the short-listed management options / strategies. Where necessary, maps have also been presented to illustrate the area relevant to the specific options / strategies.

6.3.1 Strategies to be implemented IMMEDIATELY (6 – 12 months)

6.3.1.1 EM-2: Prepare & implement a formal Entrance Management Policy

Rank: 1/22

Addressing Objectives: 2, 4, 5, 6, 7, 8, 10, 11, 12, 17

Description:

A formal entrance management policy is required to guide Council regarding artificial openings and other works to be carried out in the entrance area. This Policy will need to be signed off by appropriate government agencies who control and authorise such works (eg, DNR, DPI, Lands).

Interim Entrance Management Protocols that will form the basis of the Policy are presented in Appendix A. These protocols incorporate the following key provisions:

1. If the entrance is closed and water quality within the estuary (measured behind the berm in the normal bathing area) has degraded beyond specified criteria, Council may artificially open the entrance. Artificial opening would involve excavation of a channel through the entrance, typically located close to the rock wall. As there would be little static head to promote scour of the entrance once opened, timing of reconnection with the ocean would be critical, and would need to coincide with a large low tide (actual breakout could occur on the falling arm of the tide to maximise opportunity for self scouring of the entrance before the subsequent high tide terminates the scouring process). Timing of the opening process may be delayed by a week or so to ensure suitable tides are present to maximise opportunity for self scouring of the entrance.

Interim criteria for defining deterioration in water quality, and thus triggering entrance opening,

are given below. The site-specific validity of these criteria should be established during pilot application of the Entrance Management Policy:

- Dissolved oxygen < 4 mg/l
 - pH < 6.0
 - Temperature > 35°C
 - Secchi depth < 1.0 metres (bathing season), or < 0.5 metres (non-bathing season)
 - Faecal coliforms > 600 counts/100mL (or more than 150 counts/100mL for four consecutive records)
 - Enterococci > 60 counts/100mL (or more than 35 counts/100mL for four consecutive records)
 - Significant and unpleasant generation of odour, eg H₂S (beyond expected estuarine odours)
2. If the entrance is closed and an intermittent release of agricultural drainage waters is required, in accordance with the Floodgate Management Policy (refer Section 6.3.1.2 and Appendix B), then the entrance should be opened prior to lowering of dropboards at the floodgates.

The policy should outline responsibility for implementation, including the nomination of authorised personnel to undertake works (when necessary, in accordance with the principles of the Policy), and the preferred timing and methodology for entrance works.

Ultimately, dredging associated with meander correction works at the entrance should be included in the Entrance Management Policy. Consideration of meander correction works has not been given in the interim Entrance Management Protocols (refer Appendix A) pending the outcomes of a risk assessment for the coastal dunes (refer Section 6.3.1.3).

The interim Entrance Management Protocols (Appendix A) have also excluded any entrance dredging works for the specific purpose of establishing deep water access adjacent to the surf club boat ramp. It is considered maintaining deep water access from this ramp is unsustainable given the highly dynamic sediment environment of the entrance. Launching of boats from this ramp should be encouraged on an opportunity basis only (i.e. launch only when conditions allow). Nevertheless, it is suggested that channel dredging, when it is required, should be conducted close to the rock wall, thus facilitating usage of the boatramp and navigable access to the ocean.

The Entrance Management Policy should include periodic surveys of the Killick Creek entrance, including post storm and flood events. The frequency of surveys would be established on an as-required and opportunistic basis. Following a nominal period of implementation, the Policy may be changed in the future to incorporate a more formal program of entrance surveys if it is found that a more objective and quantifiable basis for undertaking entrance works is required.

Costs:

The cost of implementing the Entrance Management Policy is difficult to estimate, as the majority of costs will only be incurred once an artificial opening of the entrance is required. The costs for implementation of the Policy may increase significantly, if 'meander correction' dredging is included

in the future, subject to the outcomes of a dune risk assessment. Historically, meander correction has cost in the order of \$4,000 per year.

A nominal cost of \$10,000 per year has been identified for implementation of this strategy.

Consistency with other Plans and Policies:

Detailed consideration and formal management of entrances, as part of a more holistic Estuary Management Plan, is consistent with NSW Fisheries Policy and Guidelines (1999) (S.5.8.3.a-c, S5.8.4.b-d) (refer Section 1.4.7).

Works associated with the Entrance Management Policy require consent from government authorities, and as such, due process is required in assessing the impacts of the works in accordance with provisions of the *Environmental Planning and Assessment Act 1979*.

Formal entrance management is also advocated by the Healthy Rivers Commission in their 2002 Independent Inquiry into Coastal Lakes (which can be applied to Killick Creek) (refer Section 1.4.18).

6.3.1.2 FM-1: Prepare & implement a formal Floodgate Management Plan

Rank: 2/22

Addressing Objectives: 3, 9, 12, 13, 14, 15, 17

Description:

This strategy involves the preparation and adoption of a formal Floodgate Management Policy for the Killick floodgates that separate Killick Creek from the agricultural drains of Belmore Swamp and Connection Creek. The focus of the Floodgate Management Policy will be to maintain the rapid response drainage of flood waters from Belmore Swamp, but limit the persistent post-flood drainage of water from the drains when the water quality is more likely to be deteriorated.

An interim set of protocols for the Floodgate Management Policy are presented in Appendix B. These interim protocols incorporate the following key provisions:

- Dropboards will be positioned to facilitate effective management of upstream swampland by preventing drainage below a level of 0.25m AHD. Once waters fall to a level of 0.25m AHD, dropboards will be installed to this level.
- Dropboards will prevent low discharge from the upstream agricultural drains into Killick Creek, if the waters behind the drop boards do not meet the following water quality criteria:
 - Dissolved oxygen > 4 mg/l
 - pH > 5.5
 - Temperature < 35°C
 - Turbidity < 20 ntu (if turbidity is recorded)
- If water quality criteria are not met, free discharge to the estuary will be prevented, however, intermittent 'pulse' event discharges will be permitted. Dropboards will be positioned to a level

of 0.5m AHD if water quality criteria are not met. Once water levels reach 0.5m AHD, the boards will be removed and drainage permitted until water levels reach 0.25m AHD, at which time dropboards are replaced (to a level of 0.5m AHD if water quality criteria are still not met, or a level of 0.25m AHD if water quality criteria are met).

- Water levels are continuously monitored in Killick Drain by the water quality monitoring station, located approximately 80 m upstream of the floodgates.
- Total discharge from the agricultural drains to Killick Creek should not exceed the environmental flow calculated for the estuary as part of implementation of Strategy Multi-1 (see Section 6.3.3.1).
- Floodgates will be maintained to ensure that they operate effectively and efficiently (refer Strategy FM-2, see Section 6.3.2.1).
- Floodgates and the dropboards will be inspected regularly to ensure that their operation is not compromised by debris or other factors (refer Strategy FM-2, see Section 6.3.2.1).

Implementation of the Floodgate Management Policy will be dependent on data collected from the existing water quality monitoring station in Killick Drain. Information from this station is telemetered directly to Council, who then will be responsible for raising and lowering the dropboards as required. From time to time (for example if the automated water quality probe is off-line), Council officers may be required to make water level observations, or manually monitor water quality using a hand-held multiprobe.

It is recommended that new, fully interlocking dropboards be fabricated and installed at the floodgates structure, along with a more efficient and rapid mechanism for removing and reinstalling the boards.

Costs:

Some capital expenditure will be required to implement this strategy, associated with fabrication and installation of new, fully interlocking dropboards, and a mechanism for easy and efficient removal and reinstallation of the dropboards. It is assumed that capital works would cost approximately \$60,000.

With respect to on-going costs, the main costs are associated with deployment of a Council works crew on an as-required basis to operate the dropboards, and the on-going maintenance of the water quality monitoring station on Killick Creek. Although implementation of the Policy should not have major resourcing commitments on existing Council staff, the frequency of Council crew deployment is unknown at this stage. Consequently, an allowance of \$10,000 per year has been made for Council crew expenses, and \$30,000 per year for maintenance of the water quality monitoring station.

Consistency with other Plans and Policies:

Maintaining the flood discharge and drainage functions of Killick Creek enables consistency with the Upper Belmore Floodplain Management Strategy and the wider Lower Macleay River Flood Mitigation Scheme (refer Section 1.7).

The NSW Fisheries Policy and Guidelines document (1999) (refer Section 1.4.7) advocates minimal obstruction within natural waterways, and the construction of fishways to maintain fish passage.

Given that the Killick Creek floodgates are designed to maintain separation between freshwater and saltwater environments, it is considered that there would be limited need for migration of fish through the structure. The Policy and Guidelines (1999) indicates that notification to the Minister for Fisheries is required for works to existing floodgates.

6.3.1.3 EM-1: Critically assess the actual threat to the coastal dunes

Rank: 3/22

Addressing Objectives: 6, 10, 11

Description:

The beach dune to the immediate north of the Killick Creek entrance, located within Hat Head National Park, is sometimes eroded by the flowpath of the estuary, when the channel is pushed northward due to the dominant 'south to north' longshore transport processes for coastal sediment. It is understood that the dune had previously been mined for minerals, and has been artificially re-established some time since (possibly at the time of entrance training in the 1950s).

Entrances such as Killick Creek are often subject to change depending on the dominant longshore sediment transport processes occurring at the time. The fact that Killick Creek entrance is located at the southern end of Killick Beach, adjacent to the Crescent Head rocky headland, means that, locally, the dominant longshore sediment transport processes are from north to south. This is opposite to the general south to north processes that normally occur along the NSW coast, and reflect the fact that the southern end of Killick Creek more protected from the southerly and south-easterly swell by Little Nobby Point, but exposed to the north-easterly swell (which drives sediment southward along the coast).

However, from time to time, some sediment migrating northwards around Little Nobby Point will be worked onshore and transported along the foreshore where it is then deposited as a 'flood tide' shoal in the entrance to Killick Creek, adjacent to the eastern rock training wall (see Figure 6-2). The occasional formation of this shoal means that the creek channel needs to migrate westwards around the shoal to maintain connectivity with the ocean. The meander around the shoal means that the channel then traverses closer to the dunes, creating an erosion scarp on the channel face.

It is considered that the formation of the shoal adjacent to the southern wall and the associated channel meander and dune scarp formation is a part of natural processes, albeit modified due to the now almost permanently open nature of the creek entrance. During subsequent periods of northerly dominant local sediment transport, the eroded dune would rebuild, and the shoal adjacent to the southern wall would be naturally scoured (or the entrance closed if there are insufficient tidal velocities to mobilise the sand on the shoal).

It is recommended that Council refrain from correcting the entrance channel meander for one season to determine if there is any actual threat to the existing communities established on the dune, and to observe the natural dune re-building process during the subsequent period of reverse dominant longshore transport. It is considered that erosion of the dune face would not expose the estuary foreshores to any greater risk than a channel located adjacent to the rock wall, and wave energy (even for north-east swell) would be mostly dissipated within the surf zone and on the beach face. Given

that foreshore infrastructure (i.e. the caravan park) is already protected by a rock wall, this strategy will not place any additional risk on foreshore assets.

Monitoring of conditions throughout this experimental period should be carried out to help with interpretation of outcomes. Monitoring should include periodic surveys of the dune, channel and shoal positions at control sections, and accompanying observations of vegetation loss etc. MHL (2003) recommended periodic entrance survey of Killick Creek based on the outcomes of the Estuary Processes Study. At the end of the monitoring period (indicatively taken as 12 months), a detailed assessment of entrance morphodynamics should be undertaken to determine coastal processes and analyse actual risks to the coastal dune environment on the northern side of the entrance. This would provide a factual basis for either continuing to undertake corrective dredging in the entrance on an as-required basis, or for allowing the entrance channel to remain ambulatory.

Issues relating to beach access (particularly via the footbridge) in the event of realised dune erosion, will need to be managed on a case-by-case basis during the experimental period, which may then need to be considered when determining recommendations for long term management. It may be possible that a trigger for future entrance intervention is based on restrictions in access to the beach from the footbridge over Killick Creek, which would be incorporated into the Entrance Management Policy following the initial meander correction assessment.

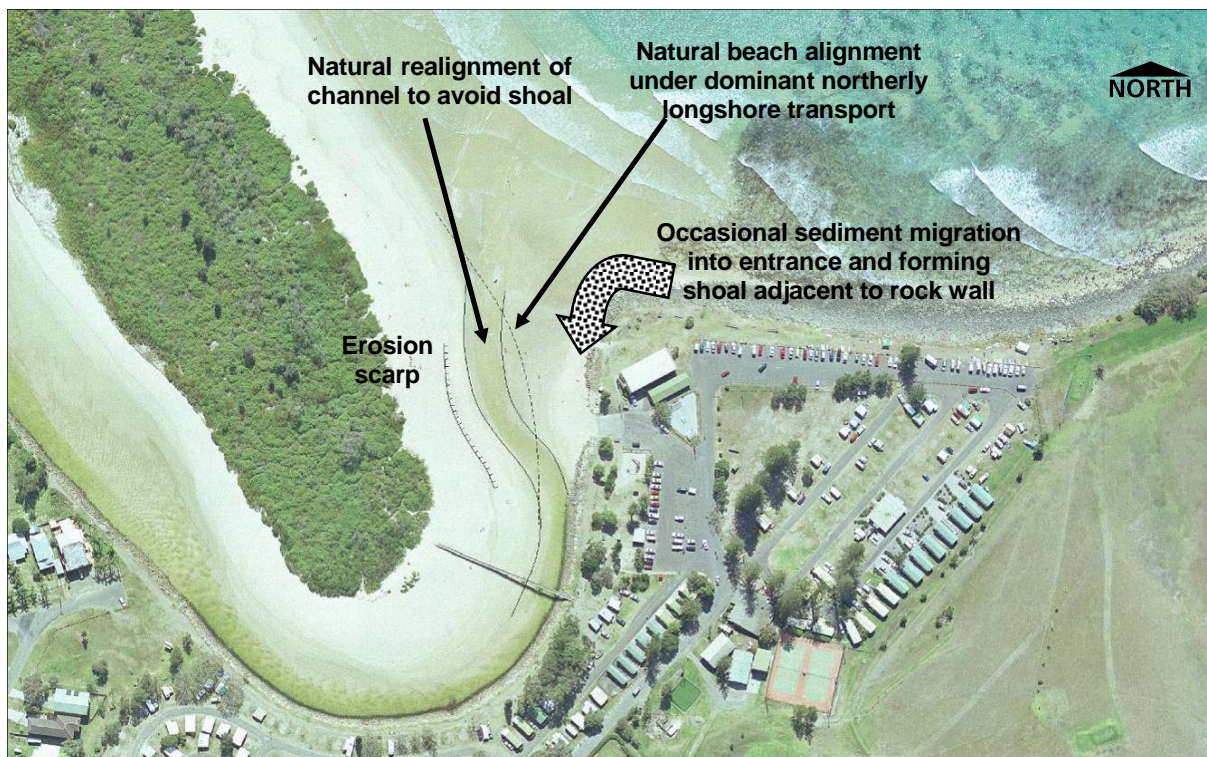

Figure 6-2 Entrance channel meander and resulting erosion scarp

Costs:

The cost of beach surveys and monitoring of the entrance condition over a 12 month period and analysis of the data are likely to be in the order of \$30,000 - \$35,000, while a further \$15,000 would be required to assess the outcomes of the surveys from a coastal morphodynamic perspective, and develop recommendations for future entrance management.

Consistency with other Plans and Policies:

This strategy is founded by the principle of establishing clear scientific evidence for artificial modification of a natural environment. This is consistent with S.5.8.4.b the NSW Fisheries Policy and Guidelines (1999) (refer Section 1.4.7), and accords with the general principles of Ecologically Sustainable Development (ESD) (i.e. it is not appropriate to expect future generations to continue undertaking intervention works in perpetuity, if the system can be permitted to adjust naturally) (refer Section 1.3.3.1).

6.3.1.4 WQ-3: Install 'leaky pits' in the caravan park

Rank: 4/22

Addressing Objectives: 1, 2

Description:

The entire area now occupied by the Crescent Head Caravan Park was reclaimed from the estuary by infilling with marine sands. As such, the soils under the caravan park are highly permeable. This options aims to help address stormwater inputs to Killick Creek by diverting low flow stormwater flows into the permeable soil rather than into the estuary.

Using the concept of 'leaky pits', the base of selected stormwater pits within the caravan park can be removed, allowing the stormwater to infiltrate directly to the underlying soil. Clearly the soil matrix at the base of the pit would need to be protected and stabilised from erosive actions of the stormwater flow during high flow events. A schematic drawing of a leaky pit concept for the Crescent Head Caravan Park is shown in Figure 6-3.

The leaky pit is aimed at intercepting low flow discharges to the estuary through the stormwater system, as well as providing some capacity to intercept and remove the first flush of the stormwater during the beginning of a high flow event. Leaky pits would be unsuitable if positioned too deep in the soil profile, i.e. too close to the permanent groundwater table. For stormwater pipes positioned below high tide level, one-way flaps would be required on the pipe outlets to prevent backwater inundation of the pits. Leaky pits would be most suitable for pits within the Caravan Park that are likely to be used during non-rain periods or where there may be the risk of detergent use (eg used by campers for dish-washing, car and boat washdown etc).

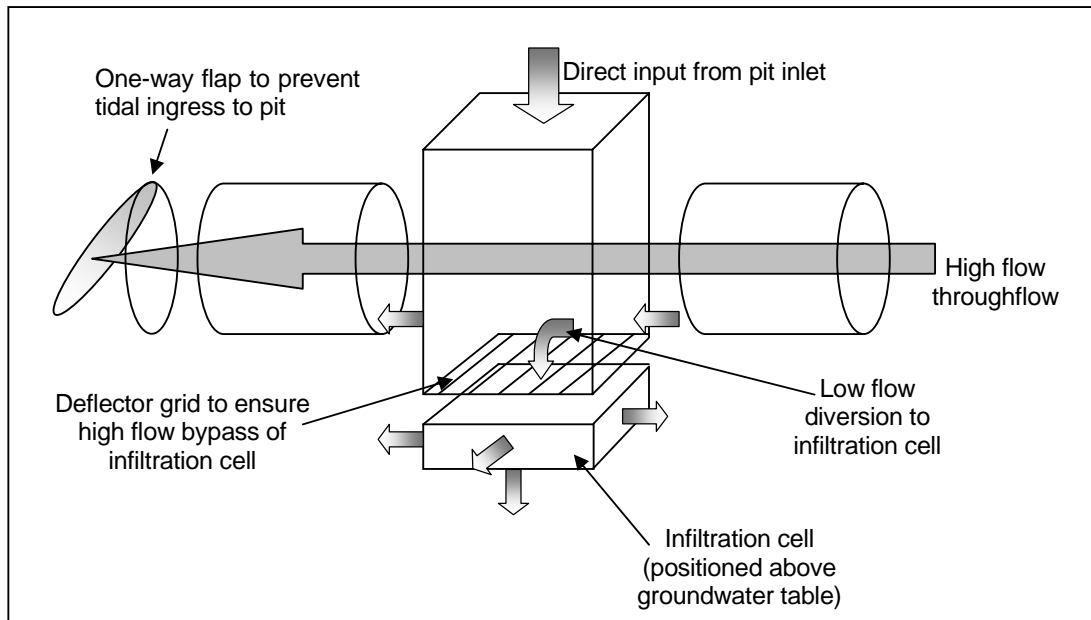

Figure 6-3 Conceptual drawing of 'leaky pit' for caravan park

Costs:

Following a generic detailed design, costing approximately \$8,000, existing pits could be converted to 'leaky pits' for an estimated cost of about \$2,000 each. It is estimated that about 10 stormwater pits could be converted to leaky pits within the Caravan Park, for a total construction cost of about \$20,000.

Consistency with other Plans and Policies:

Leaky pits are not identified within the Crescent Head Stormwater Management Plan, however, they are not inconsistent with the principles under which the Stormwater Management Plan was developed. Devices recommended within the Stormwater Management Plan focussed on treatment of litter and petro-chemicals, whereas the leaky pits aim to remove low flow discharges to the creek that potentially contain faecal and nutrient contamination.

Preventing pollution of estuaries emanating from stormwater drains is advocated by NSW Fisheries Policy and Guidelines (1999) (refer Section 1.4.7). Specifically, S.5.5.4.d requires low flow inputs to be of better quality than that already in the stream, while S.5.5.4.g states that nutrient concentrations in stormwater and surface runoff must comply with ANZECC (1992) guidelines. Furthermore, S.5.5.4.h of the Policy and Guidelines document indicates that stormwater from roads, carparks and other paved surfaces should be channelled away from aquatic habitats and filtered – leaky pits provides an accepted means for diverting and filtering low flows within an existing stormwater system.

Interception of potentially pollutant-laden low flow discharges to Killick Creek would be entirely consistent with the principles of the NSW Estuary Management Policy (Section 1.3.2) and Coastal Policy (Section 1.3.3), wherein the natural estuarine environment is to be protected, rehabilitated and improved.

6.3.1.5 WQ-12: Continue to monitor for bacteria (eg faecal coliforms and enterococci)

Rank: 5/22

Addressing Objectives: 2

Description:

Given the utilisation of Killick Creek for recreational purposes, particularly during the summer holiday season, it is important that the water is continuously monitored of bacteria. Elevated levels of bacteria may be indicative of high elevated levels of pathogens, which may cause illness to people exposed to the water.

Monitoring of bacteria (faecal coliforms and enterococci) should be carried out weekly, as well as every day for three days following rainfall events. Monitoring only needs to be taken from one location in the estuary, as the recreational usage is highly concentrated in the entrance channel adjacent to the caravan park. Monitoring should be taken from the middle of the creek on the outgoing tide approaching low water. Samples would then need to be taken to Council's microbiological laboratory for immediate analysis.

It is anticipated that collection of water quality samples for bacterial analysis could be conducted by Council staff. A locally based officer, if possible, would ensure that sampling is done in quick response to rainfall.

Monitoring would only need to be carried out when there is reasonable use of the estuary by bathers. Therefore, monitoring is unlikely to be required for about five months of the year (May to September).

Permanent signage should be installed advising bathers of potential risks due to poor water quality for periods during and immediately after rainfall events, as well as during periods when the entrance is closed.

Following collection of at least one month of data, which incorporates both dry periods and post-rainfall events, the data should start to be analysed to determine if there is any correlation between rainfall intensity, duration etc, and resultant bacteria levels in the estuary. Data should then be added to the statistical model on a monthly basis, as available, to reinforce the correlations developed. If a reasonably defensible correlation between rainfall and bacteria levels is established, advisory signage can be adjusted as necessary to advise of 'go / no go' periods following rainfall (eg no swimming for X hrs after the end of a rainfall event that exceeds X mm in total).

Costs:

Assuming that about 100 water samples would require analysis during the course of the year, the cost for bacterial monitoring in Killick Creek would be in the order of \$2,500. This cost is in addition to existing Beachwatch and Council monitoring program located outside the Killick Creek estuary.

Signage advising public of suitability for swimming, as an outcome of the monitoring, would cost in the order of \$1,000.

Consistency with other Plans and Policies:

On-going bacterial monitoring of Killick Creek is consistent with the recommendations of the Crescent Head Stormwater Management Plan (refer Section 1.4.16) and the National Water Quality Management Strategy (NWQMS) developed in tandem with preparation of water quality guidelines (ANZECC, 2000).

It is considered that Council has a duty of care to residents and visitors to Crescent Head to determine the water quality of Killick Creek, and inform the community of potential risks to public health associated with the creek environment.

6.3.1.6 WQ-1: Implement Crescent Head Stormwater Management Plan

Rank: 6/22

Addressing Objectives: 1, 2

Description:

One of the major pollutant inputs to the Killick Creek estuary is the Crescent Head stormwater system. There are a number of stormwater drains that discharge directly to the estuary, mostly through the Caravan Park. The size of these drains, and the size of their associated catchments, varies significantly, some draining just local areas of the caravan park, and some draining large areas of the Crescent Head urban area. Some urban stormwater is also discharged into the Muddy Creek backwater, which connects with the estuary further upstream.

As discussed in Section 1.4.16, a Stormwater Management Plan for Crescent Head was prepared (GHD, 2003), and recommended specific actions be undertaken in order to reduce the level of pollutants discharging to Killick Creek via the stormwater system. A number of the actions recommended in the Stormwater Management Plan have already been carried out by Council. A major recommendation of this Estuary Management Plan is therefore to continued implementation of the Stormwater Management Plan (GHD, 2003). Management actions recommended by the Stormwater Management Plan included:

- Routine and event-based water quality monitoring within the stormwater system and the receiving water (ie Killick Creek);
- Installation of a number of treatment devices to remove litter from the stormwater prior to discharge into Killick Creek (and one to remove oil and grease);
- Increase the number of sullage disposal points in the Caravan Park, so that waste is not accidentally or intentionally directed to the stormwater pits by users of the park; and
- Further community education, including drain stencilling, information on dog droppings, nutrient impacts and management, reporting of sewer overflows, and using students to monitor stormwater quality.

Costs:

Costs for implementation of some of the works recommended in the Crescent Head Stormwater Management Plan (relating primarily to end of line treatment devices) are detailed in GHD (2003). It

is expected that funding for these works may be available (both in Council and beyond Council) through the estuary / environmental management avenues and urban stormwater management avenues. Council may also explore avenues to obtain funding from visitors and tourists to Crescent Head and surrounding areas, or alternatively, may increase fees for use of the (Council-operated) Crescent Head Caravan Park to fund some of the Stormwater Management Plan recommendations, particularly those related to works within the Caravan Park.

A review of the methods and recommendations of the Stormwater Management Plan should be carried out, at an estimated cost of \$5,000, in light of Estuary Management Plan objectives, and to identify tasks completed, address problems faced to date, and reconsider future implementation approach.

Consistency with other Plans and Policies:

Minimisation of stormwater pollution to estuaries is enshrined within many other Plans and Policies including the Catchment Action Plan (refer Section 1.4.19.2), the NSW Fisheries Policy and Guidelines (1999) (refer Section 1.4.7) and the HRC (2002) Independent Inquiry into Coastal Lakes (refer Section 1.4.18).

6.3.1.7 EM-3: Install signage outlining the hazards of the entrance

Rank: 7/22

Addressing Objectives: 5

Description:

Some community members have raised concerns regarding potential risks for swimmers who bath within the entrance channel of Killick Creek, and are subject to some strong currents from time to time. The estuary is a highly regarded for providing sheltered bathing conditions, and therefore, strong currents may take some bathers by surprise, particularly young children.

Whilst it is not proposed to modify the entrance to reduce tidal currents through the entrance channel, it is considered prudent to provide advisory signage indicating that tidal flows in the channel may occasionally be hazardous to some swimmers, particularly the young. The sign should advise bathers, and parents of younger children, to observe conditions in the channel prior to entering the water. The sign should also include diagrammatic information for non-English speaking people (refer Figure 6-4). Such signage should be placed adjacent to the main access points to the water, while similar educational material should be provided to all users of the Caravan Park.

Costs:

Costs associated with preparation and installation of the sign are considered to be relatively small, in the order of approximately \$1000. Maintenance of the sign would be required from time to time.

Consistency with other Plans and Policies:

Council has a duty of care to notify the public of health and safety risks in areas that are highly utilised by the public.

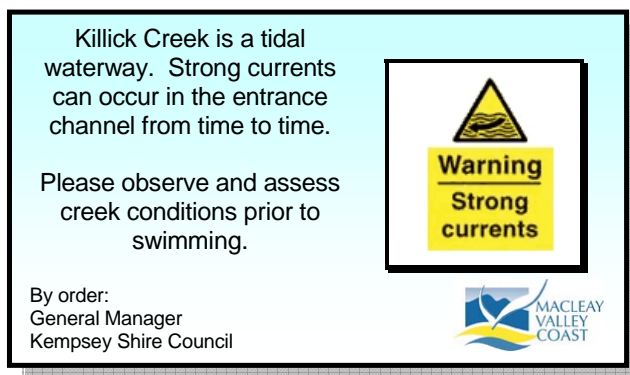

Figure 6-4 Example of signage for Killick Creek regarding swimming hazards

6.3.2 Strategies to be implemented in the SHORT TERM (1 – 3 years)

6.3.2.1 Sed-3: Remove sediment shoals in Killick Creek which inhibit tidal flushing and flood discharge

Rank: 8/22

Addressing Objectives: 2, 3, 6, 7, 9, 10, 17

Description:

Sediment shoals have formed within Killick Creek, which affect the hydrodynamics of the estuary. Sediment accumulation at the entrance limits the extent of tidal flushing and ocean exchange within the waterway, and has in the recent past caused complete closure of the entrance (thus preventing exchange and tidal flushing entirely). The most recent hydrosurvey of Killick Creek (July 2001), reproduced in Appendix D, was carried out a few months after significant flooding, and thus represents a relatively scoured condition compared to present day conditions. A new hydrosurvey is required to fully appreciate the extent of marine sand ingress since July 2001, and thus provide a basis for flood tide delta dredging.

Fluvial sediment has also accumulated further upstream, particularly in areas that were artificially deepened as part of previous flood mitigation works. Illustrating the consequence of sediment shoals, water levels immediately downstream of the Killick Creek floodgates do not have the same degree of tidal variation as the most downstream sections of estuary, with low water levels being controlled by the crest elevation of downstream sediment shoals (refer Figure 2-2).

This option involves the removal of sediment from within the Killick Creek waterway in order to maintain the tidal and flood hydrodynamic conditions that have characterised the estuary for the past 30 – 50 years. Of most concern is the accumulation of marine sand on the flood tide delta. Whilst it is recognised that removal of sand from a flood tide delta is usually futile (with dredged areas infilling relatively quickly under tidal and wave action), removal works could be optimised to maximise longevity whilst still providing the desired hydrodynamic benefits. In this regard, it is considered that dredging could initially be carried out to restore a deeper channel through the upstream end of the

flood tide delta (between the Caravan Park and Muddy Arm), as shown in Figure 6-5. Dredging any closer to the entrance than that shown in Figure 6-5 would likely be short-lived.

A volume of approximately 10,000m³ would need to be dredged from the upstream end of the marine flood tide delta, comprising medium to fine-grained quartzite marine sands, with a small fines content.

Dredging within the active coastal environment is generally discouraged by State Government, unless the material can be retained within the coastal compartment. In this regard, it may be possible to dispose of the dredged material locally within Killick Creek (refer Figure 6-5), or pumped over the dunes to the ocean beach, where it could be used for general beach nourishment. It is understood that this beach has experienced shoreline recession in recent years, and thus would benefit from a local sand nourishment program.

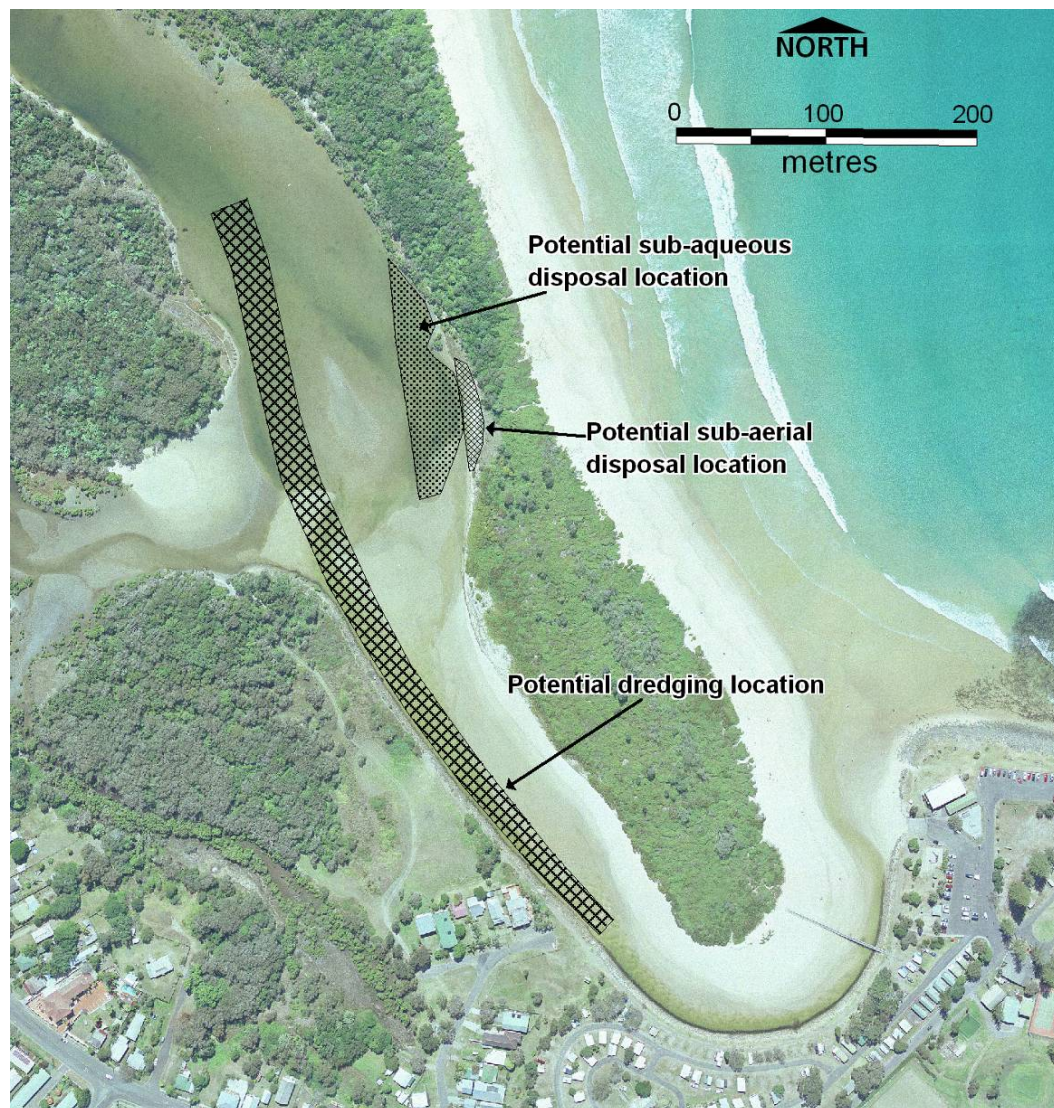

Figure 6-5 Possible dredging and disposal locations in lower reaches of Killick Creek

Costs:

Costs for dredging a channel through the upstream end of the marine delta would be dependent on the volume of sediment to be removed, the method of removal and the location of sediment disposal. Based on an indicative volume of approximately 10,000m³, and a nearby sub-aerial or sub-aqueous disposal location (or adjacent ocean beach nourishment), an allowance of \$200,000 has been assigned for initial accounting purposes, while necessary surveys and environmental assessments would total a further \$70,000 approximately.

Consistency with other Plans and Policies:

The NSW Fisheries (1999) Policy and Guidelines document (refer Section 1.4.7) provides guidance on dredging activities. A dredging permit is required from NSW DPI (formerly Fisheries) unless a permit is issued by another NSW Government Department.

Provisions of SEPP-35 (refer Section 1.4.2.2) should be used to help facilitate the approvals process. SEPP-35 would avoid the need for assessment by Council in accordance with their LEP and the standard EP&A Act Part IV Section 79C heads of consideration process.

Rezoning of the waterway (refer Section 6.3.3.5) as part of the LEP review process currently underway by Council may also facilitate dredging works within Killick Creek in the future, providing that maintenance dredging is permitted within the zoning prescribed to Killick Creek.

*6.3.2.2 FM-2: Upgrade floodgates to ensure they operate effectively*Rank: 9/22

Addressing Objectives: 3, 9, 13, 14, 15, 17

Description:

It is understood that the existing Killick floodgates do not, at times, operate effectively and do not provide a complete seal to waters moving upstream from the estuary. Consequently, the agricultural drains in Belmore Swamp and Connection Creek are apparently affected by salinity, which limits the potential for reinundation of the land (as part of ASS management practices).

Past inefficiencies in floodgate operation are likely to be the result of blockages within the culverts and floodgates structure (eg build-up of debris etc), and / or deterioration of the floodgates and culverts infrastructure, and / or poor design of the gates. To address the issue of blockages, it is recommended that Council officers carry out regular inspections of the structure to determine if there is a build up of debris, or there is any ill-operation of the floodgates. It is expected that daily inspections of the structure should be carried out for those periods when the floodgates are actually in operation (based on the interim Floodgate Management Plan, the floodgates would be operational whenever the dropboards have been removed, that is, when water levels in the agricultural drains are higher than 0.25m AHD [to be confirmed following preliminary implementation of the Plan] and when the water meets the water quality criteria, as specified by Floodgate Management Plan, Strategy FM-1, refer Section 6.3.1.2). If debris is observed within the floodgates structure, then a Council crew will be deployed to redress the situation. If it is found that debris build-up occurs frequently, requiring a significant demand on Council to remove such material, then the construction of a

structure immediately upstream of the floodgates should be considered to intercept and hold the debris away from the floodgates. This structure would also need to be cleared, but probably less often, and would be less crucial to the management of agricultural lands, as it would not compromise the operation of the floodgates and allow saline water to penetrate upstream.

A conditions assessment is recommended to thoroughly inspect and review the condition of the floodgates and to determine their existing and future capacity to maintain functionality. If the assessment finds that the floodgates are in poor condition, then they should be repaired, if possible, or replaced in entirety with new gates. The conditions assessment should also consider the efficiencies of the floodgate arrangement to determine if there are any changes to the structure that could be made to improve their operation and functionality (for example, if the gates are too heavy, a large static head would be required to open the gates – would a greater number of smaller, lighter gates operate more effectively than a fewer number of larger, heavier gates?). It may be found that floodgate efficiencies can be improved by achieving a lower low tide level on the downstream side of the floodgates (thus generating a greater head difference across the structure), which should be achieved through implementation of Strategy Sed-3 (see Section 6.3.2.1).

Costs:

Costs for a conditions assessment of the floodgates are likely to be in the order of \$5,000. Repairs to the floodgates may cost in the order of \$40,000, while complete replacement of the floodgates could cost between \$100,000 and \$200,000. The construction of a debris barricade upstream of the floodgates is likely to cost in the order of \$40,000, depending on design, size and construction materials.

Consistency with other Plans and Policies:

Given Killick Creek's role in regional flood mitigation for the Macleay and Maria-Hastings catchments, the works described in this strategy are considered to be consistent with the Upper Belmore Floodplain Management Strategy (refer Section 1.7) and overarching Macleay River Floodplain Management Plan.

6.3.2.3 WQ-14: Prepare a DCP for future development within Crescent Head

Rank: 10/22

Addressing Objectives: 1, 2

Description:

This strategy involves the preparation of a new site-based Council Development Control Plan (DCP), or modifications to an existing DCP, which applies to all future development within Crescent Head and the greater catchment area of Killick Creek. The DCP would define a series of controls on development, such as the following:

- Inclusion of a 'best practice' total water cycle management system. Best practice would include implementation of Water Sensitive Urban Design and Integrated Water Cycle Management (which would include stormwater harvesting and reuse). Requirements for total water cycle

management should supplement the existing state government requirements under the BASIX building sustainability index system. Further details of 'best practice' water cycle and stormwater management are available at www.wsud.org and www.clearwater.asn.au;

- Identification of areas that are too close to the estuary for permissible development. This buffer should be based on maintaining public amenity and foreshore access around the estuary, and preserving the existing and future riparian values of the estuary. An interim setback of 50 metres from the estuary shoreline should be adopted until a more rigorous assessment can be conducted;
- All developments (including redevelopments) within the catchment to be subject to a once-off catchment levy, which will be used for future environmental improvement works within the waterway and catchment area. Council may consider waiving this levy for developments that incorporate on-site stormwater management (e.g. include rainwater tanks), greywater reuse or other environmentally positive outcomes (refer 1st dot point).

Kempsey Shire Council is currently reviewing their LEP, which should include implementation of this strategy. Council has also recently prepared a draft DCP for Crescent Head, with a clause on stormwater management. It is envisaged that the above provisions could be incorporated into the existing draft DCP as an alternative to a new DCP.

Costs:

Costs for preparing the DCP would be met through existing Council resources. State Government is providing funding to Councils to modify planning controls associated with recent changes to the *Environmental Planning and Assessment Act 1979*. Council may wish to undertake community education of any new development controls, at an estimated cost of \$5,000.

Consistency with other Plans and Policies:

Place-based DCPs, such as the plan proposed for this strategy, are recommended as part of recent planning reform, and should support the Local Environmental Plan (currently under review). Addressing future inputs to receiving waters through controls on development within the catchment represents sound integrated management and planning. It is also advocated by Healthy Rivers Commission (2002) (Section 1.4.18), while general protection of natural environments is espoused by the Estuary Management Policy (Section 1.3.2) and the Coastal Policy (Section 1.3.3), under which direction this Estuary Management Plan has been essentially prepared.

6.3.2.4 FM-6: Continue trials of improved backswamp management with targeted education of agricultural landholders

Rank: 11/22

Addressing Objectives: 15, 16

Description:

Changes to the management and operation of the Killick Floodgates are likely to have consequences on the upstream landholders with respect to their existing land management practices of the Belmore Swamp agricultural lands.

To coincide with changes to the operation of the floodgates, the upstream landholders should be targeted for education regarding the floodgates, the implications for their land, and alternative practices that can be adopted, as appropriate. Education should focus on the past impacts of agricultural management on the estuarine environment of Killick Creek, and present sound justification for the change to the operation of the floodgates. The Macleay River Floodplain Committee commenced a landholder awareness program in 2000. Therefore, the aim of this strategy is to build on and expand the consultation already undertaken, drawing specific relevance to Killick Creek and the impacts of agricultural management on the estuarine environment.

Given the relatively small number of recipients of the targeted education, methods of delivery can be personal, and customised to suit each individual. Education should be facilitated through the CMA and DPI (Agriculture), as well as Council. As part of the educational process, a system for on-going consultation with the landholders should be established, including single point contact with an appropriate representative.

Costs:

Design, preparation, reproduction and distribution of educational material are likely to cost in the order of \$50,000.

Consistency with other Plans and Policies:

This strategy is supported by a wide range of Plans and Policies, including the National Strategy for Management of Coastal Acid Sulphate Soils, the State Coastal Policy (including the key goal of providing information to enable effective management of the coastal zone – refer Section 1.3.3), and the State Wetlands Management Policy, as well as the Acid Sulfate Soils Management Advisory Committee (ASSMAC) Guidelines.

6.3.2.5 FM-4: Agricultural and economic assessment of land practices

Rank: 12/22

Addressing Objectives: 16

Description:

Agriculture has dominated the Macleay River floodplain for more than 100 years. Areas such as the Belmore Swamp have been particularly viable as agricultural lands, as floodwaters can be drained off the land relatively quickly, while during periods of low rainfall, water can be extracted from the river to irrigate pastures. Effective drainage of floodwaters off low lying lands is crucial to the success of agriculture in these areas, as extended inundation would be detrimental to the preferred pastures, such as kikuyu, couch and buffalo grass.

It is expected that in the future, given the anticipated rise in sea levels, low-lying swamp lands will become more difficult to drain (as the ocean will be at a higher level). Unless mechanical assistance to drainage (ie pumping) is provided, there will be some point in the future when sea level has rise to the extent that reduced drainage of water from the swamps no longer allows for economically viable agricultural production of the land. It is recommended that an agricultural and economic assessment of the lands around Belmore Swamp be undertaken to determine the likely changes in sea level

required to render the area uneconomic for agricultural production, and thus, provide a timeframe for which agricultural practices are likely to be phased out (in the absence of mechanical assistance of drainage, eg more extensive levees and high volume, low head pumps to remove water from the floodplain areas). The agricultural aspects of this study should consider options and alternatives that cater for future changes to the environment. Options may include changes to pasture selection, additional drainage infrastructure and alternative landuse demands.

The outcomes of this assessment should be used to define the future requirements for drainage and floodwater evacuation, and thus, will guide the management and operational procedures for the Killick floodgates in the future. Therefore, this assessment has direct relevance to Killick Creek, and has been incorporated into this Estuary Management Plan. An assessment of this type was first mooted by MHL (2003) as an outcome of their Estuary Processes Study for Killick Creek.

Costs:

Costs associated with conducting this assessment are likely to be in the order of \$100,000, depending on the scope of the project. The works should be carried out in close consultation with DNR and the Department of Primary Industries (DPI), as the results for Belmore Swamp would be directly relevant to many agricultural floodplain lands throughout the NSW north coast area. The final scope of the project may be expanded to include areas beyond that directly relevant to Killick Creek, depending on the requirements of DNR, DPI and Council. It is anticipated that federal funding may be available through the CMA to determine the agricultural and economic consequences of future climate change.

Consistency with other Plans and Policies:

It is envisaged that the agricultural and economic assessment of land management practices in low-lying, flood-prone and acid sulfate swamplands would be consistent with strategies developed as part of the Catchment Action Plan (refer Section 1.4.19.2). The outcomes of the assessment would determine long-term sustainability of farm management practices, and indeed economic viability of existing landuses, in light of projected future sea-level rise and other climate changes.

This strategy would also be consistent with goals of the Coastal Policy (Section 1.3.3), including recognising and accommodating natural processes and climate change, promotion of Ecologically Sustainable Development, and providing for ecologically sustainable human settlement.

6.3.2.6 WQ-13: Water quality monitoring program for Killick Creek

Rank: 13/22

Addressing Objectives: 1, 2

Description:

A formal program of water quality monitoring and assessment should be developed and implemented for Killick Creek. Formal water quality monitoring of Killick Creek was a major recommendation of the Killick Creek Estuary Processes Study (MHL, 2002), given the dearth of consistent water quality data for the estuarine system downstream of the floodgates (to date only a small number of once-off studies of water quality have been conducted within the estuary). The objectives of the proposed

water quality monitoring program would be to monitor the quality of water within the Killick Creek to:

- determine its acceptability from ecological and human usage perspectives,
- to identify the main factors that threaten the acceptability of the water quality both at present, and in the future, and
- be carried out at a range of temporal and spatial scales that allows for achieving the first two points above.

Monitoring should be carried out at a range of temporal and spatial scales, and should incorporate a range of water quality constituents, reflecting the full spectrum of physical, chemical, geochemical and biological processes occurring within the estuary. A detailed water quality monitoring program should be developed after consideration of available funding, human resourcing, laboratory constraints and physical / environmental limitations of the estuary. A 12 month pilot program should be implemented initially to determine the suitability and robustness of the program, and to recommend modifications prior to implementation of the water quality monitoring program proper.

It is anticipated that the water quality monitoring program for Killick Creek would cover at least 4 sites (two in the lower estuary - one near the stormwater outfalls and one further away from stormwater influences; and two in the upper reaches - one downstream of the floodgates and one in the blind northern arm of Killick Creek, refer Figure 6-6 for example of sites). Sampling would be carried out at routine intervals, to determine predominant conditions, but would also be supplemented by additional sampling during and immediately after significant catchment inputs (generated from rainfall), particularly targeting inputs from stormwater drains at Crescent Head, and inputs from the agricultural drain via the Killick Floodgates. Depending on the outcomes of a pilot study, further monitoring sites may need to be considered for the program, which target specific inputs to the systems, such as within the Crescent Head stormwater system, and upstream of the floodgates in Killick Drain (which may then only need to be monitored during wet weather conditions). Water quality monitoring within the Crescent Head stormwater system is a specific recommendation of the Crescent Head Stormwater Management Plan (refer Strategy WQ-1, see Section 6.3.1.6).

Water quality constituents included in the monitoring program would be targeted towards the expected catchment inputs and internal processes occurring within the estuary. As such, monitoring may include a range of nutrient components (TN, NO_x, NH₄, TKN, TP, FRP, Si, TOC), physical components (DO, salinity, temperature, pH, turbidity, TSS), biological components (algal counts and composition, chlorophyll-a, CDOM), and bacterial components (faecal coliforms, enterococci, faecal sterols, δ¹⁵N isotopes). Not all constituents would need to be assessed for every monitoring episode.

Specific monitoring episodes may also target multiple sampling through the water depth, to provide snap-shot indications of variation in water quality from the bed to the surface. Whilst it is expected that the downstream sites would be relatively well mixed, stratification of the upper reaches may be possible, which would be targeted by such monitoring.

Costs:

Costs for water quality monitoring of Killick Creek would depend on the parameters assessed and the frequency of sample collection. An on-going budget of \$30,000 per year for water quality monitoring of Killick Creek would be required to implement a thorough and robust monitoring program.

Pilot monitoring for a period of about 12 months is recommended to optimise the monitoring program (including sites, parameters, frequency). Costs for establishing programs, implementing the pilot program and reviewing outcomes (leading to a final monitoring program for on-going application in Killick Creek) would likely cost in the order of \$60,000 (and would precede the on-going monitoring outlined above).



Figure 6-6 Suggested Water Quality Monitoring Sites for Pilot Program

Consistency with other Plans and Policies:

A detailed water quality monitoring program is essential to managing the estuary within an 'adaptive management' framework, which forms part of the principles of Ecologically Sustainable

Development (refer Section 1.3.3.1). Without monitoring, it will be difficult to gauge the success, or not, of strategies implemented under the Plan.

Also, under the *Local Government Act 1993*, Council has an obligation to report on the condition / state of waterways, including Killick Creek. Without consistent and informative monitoring, Council would be unable to report on the condition of this estuary.

6.3.2.7 FM-7: Restore the entrance training rock wall to an acceptable engineering standard

Rank: 14/22

Addressing Objectives: 6, 18

Description:

The entrance rock training wall located adjacent to the Crescent Head Caravan Park was constructed more than 50 years ago. Whilst it has served its general purpose since that time, it is currently in a dilapidated condition, and represents a notable hazard to the public utilising the entrance channel for recreation.

The existing rock wall should be rebuilt to current engineering standards. This would include provision of a geotextile backing filter, more substantial toe foundation, and rock of a size that cannot be easily man-handled, or dislodged under flood velocities or stormwater discharge flows. It is expected that some of the existing rock could be reused on-site, however, a substantial quantity of new material would also be required.

Revegetation of the top-of-bank area (refer Strategy Ecol-3, Section 6.3.2.8) should be carried out immediately following reconstruction of the rock wall.

Costs:

Assuming that only a 300 metre length of rockwall needs replacement (ie the section immediately in front of the Caravan Park), with a total wall height of approximately 3 metres, the cost of the wall reconstruction would be in the order of \$200,000. Detailed design and specification of the works would cost approximately \$30,000.

Consistency with other Plans and Policies:

The restoration of an existing rock wall would be less problematic than construction of a new wall, as the works could be regarded as maintenance (thus potentially avoiding the need for consent under existing environmental planning frameworks). Nonetheless, consultation would need to be carried out with appropriate authorities, including DNR and DPI-Fisheries, prior to undertaking the works.

The works are considered necessary to protect land and assets located immediately behind the existing rock wall. The works would also benefit the overall Lower Macleay Flood Mitigation Strategy, as a new wall would improve the efficacy of flood discharges from the entrance. The improved condition of the wall would also reduce the potential risks and hazards to the public, and thus is considered to be in accordance with Council's duties under the *Local Government Act 1993*.

6.3.2.8 Ecol-3: Undertake riparian re-vegetation along the foreshores

Rank: 15/22

Addressing Objectives: 11

Description:

Vegetation around some of the Killick Creek foreshores is absent, or is significantly limited in comparison to natural conditions. Riparian vegetation provides a critical link between terrestrial and aquatic environments, and is utilised by unique faunal assemblages, including many types of birds. Riparian vegetation around the Killick Creek estuary should be re-established to a natural condition, as much as practical (given landowner issues and future development considerations, especially regarding Crown land), to maximise the ecological benefits and values of the estuary. This would comprise a minimum 20 to 30 metre vegetated buffer from the top of the estuary bank.

There are some sections of the estuary foreshore that cannot be fully revegetated to such a buffer width, such as in front of the caravan park, however, some selected plantings of trees (e.g. Norfolk pines) and low bushes (e.g. Lomandra) adjacent to camping sites and walkways in these sections would still provide some habitat (e.g. osprey nesting opportunities). Revegetation should form an important element of the Plan of Management for the Crescent Head Caravan Park. Vegetation could also be used to help restrict pedestrian access, such as along the top of the rock wall. Revegetation works should be co-ordinated with restoration of the entrance rock training wall (refer Strategy FM-7, Section 6.3.2.7), so that new vegetation does not need to be removed in order to gain access to the rock wall.

A map of areas that should be targeted initially for revegetation around the Killick Creek estuary is provided in Figure 6-7. These lands cover private and public lands (Crown or Council managed). Revegetation of privately owned lands and Crown land should be pursued following agreement with landholders.

Costs:

Revegetation and increasing biodiversity is a major objective of the Catchment Management Authority (CMA). Therefore, it is likely that funding could be provided from the CMA for undertaking some or all of these revegetation works.

An initial vegetation plan would need to be prepared (at an approximate cost of \$5,000), outlining appropriate species, planting densities, etc, followed by supply of seedlings and all necessary resources. It is assumed that volunteer labour could be used to carry out revegetation works, however, costs for providing plants and resources would still amount to approximately \$10,000 per year (for 3 to 4 years, say). Vegetation may need maintenance during the first few years, at about \$2,000 per year.

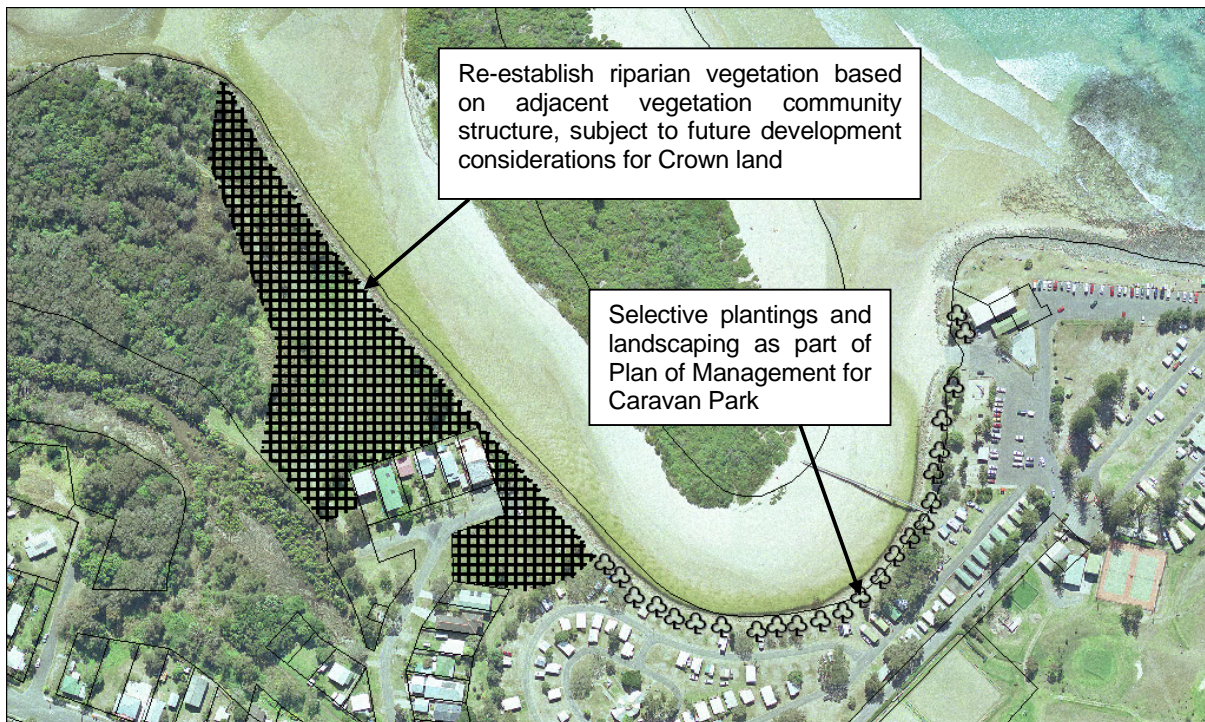

Figure 6-7 Areas for Riparian Revegetation around Killick Creek

Consistency with other Plans and Policies:

Revegetation leading to increased biodiversity is a key strategy of the Northern Rivers Catchment Action Plan (refer Section 1.4.19.2). Riparian vegetation is considered to be highly valued from an ecological perspective, due to its interface between aquatic and terrestrial environments. Protection of riparian vegetation is enshrined within most management plans relevant to the sustainable management of waterways, including Policy and Guideline documents from NSW DPI, DEC and DNR, including the Estuary Management Policy (Section 1.3.2) and the Coastal Policy (Section 1.3.3).

Revegetation will occur on Crown land, and as such, is subject to consideration of future use of the land by government. In response to the draft Estuary Management Plan, the Department of Lands submission made note that the Crown land adjacent to Killick Creek has long been identified by the Department as having commercial potential within recreational and/or tourism related landuses. As such, proposals for revegetation of this land would need to consider the potential for the land to be developed in the future, subject to satisfying statutory obligations under the Crown Lands Act and necessary environmental assessments, thus not sterilising the land from future options.

6.3.3 Strategies to be implemented in the MEDIUM TERM (3 – 5 years)

6.3.3.1 Multi-1: Carry out an environmental flows assessment for Killick Creek

Rank: 16/22

Addressing Objectives: 3, 6, 9, 10, 13, 14

Description:

The environmental flow for an estuary can essentially be considered as the amount of freshwater input required to maintain healthy estuarine ecosystem structure and functionality. Flows in excess of this amount, as well as flows less than this amount, would potentially have detrimental impacts on the estuarine ecosystem.

Determining the environmental flows for the Killick Creek estuary is considered prudent, as given the use of the estuary for floodplain drainage, it is likely that the freshwater flows to the estuary have exceeded the natural requirements. Consequences of overloading or underloading the estuary with freshwater should also be considered as part of the assessment. As such, the scope of the environmental flows assessment would be multi-disciplinary, with a strong focus on the assessing and defining the ecological integrity of the estuary.

There are a number of methodologies that have been developed to assist in assessing environmental flows for estuaries, including work done by Pierson *et al.* (2002), Gippel (2002), and the Queensland DPI.

Calculation of the environmental flows for Killick Creek will provide a scientific basis for modifying the function of the Killick floodgates. As present, the floodgates have limited functionality due to a build up of sediment between the gates and the lower estuary (which artificially keep low tide levels high on the downstream side of the gates, thus preventing any substantial outflow from the agricultural drains). Until the environmental flows assessment is conducted, management of the Killick floodgates should follow an interim set of guidelines, which are presented in Appendix B of this document.

Environmental flows should be determined in close consultation with the Coast and Estuary Management Committee and DNR, who have some experience in this process. Consequently, DNR should be a key contact and should help devise a suitable scope and objectives for the project.

Costs:

Calculation of environmental flows and associated ecosystem consequences of higher and lower flows is likely to cost in the order of \$40,000 to \$50,000 if tendered to a consultant. DNR may have the resources to carry out this study internally. Modifications to the Floodgate Management Policy may be required as an outcome of the study findings.

Consistency with other Plans and Policies:

Management of water, and environmental flows in particular, is guided by the *Water Management Act 2000*. Collection of factual data regarding the potential impacts of Belmore Swamp flood discharges into Killick Creek will provide defensible arguments for maintaining existing usage, or modifying usage. Policies and Guidelines, such as NSW Fisheries (1999) (refer Section 1.4.7) call for management of natural resources based on factual data rather than speculation and anecdotal accounts.

Given that the overarching goal of this strategy would be establish upper limiting flow conditions that do not result in degradation of the estuary, it would also be consistent with the objectives of the Estuary Management Policy (Section 1.3.2) and the goals of the NSW Coastal Policy (Section 1.3.3).

6.3.3.2 FM-3: Hydrological and hydraulic study of the Belmore Swamp area

Rank: 17/22

Addressing Objectives: 15, 16, 17

Description:

One of the major factors influencing the condition of Killick Creek is runoff from the Belmore Swamp agricultural lands. The Belmore Swamp drainage system was constructed more than 50 years ago, with some recent additions in the 1970s. It is considered that a numerical hydrological and hydraulic assessment of the Belmore Swamp area should be carried out to determine if drainage of the lands through Killick Creek is still the most appropriate approach for management of these lands. This investigation was previously recommended by MHL (2003) based on outcomes of the Killick Creek Estuary Processes Study.

The hydrological and hydraulic model assessment should utilise current modelling technology to simulate existing flood drainage from the swamp, and assess the performance of the current flood mitigation scheme. The models should then be used to assess a range of alternative options associated with proposed modifications to the drains and floodgates, as recommended by this Estuary Management Plan (including the interim Killick drain floodgate management protocols [refer Section 6.3.1.2] and the construction of a block in Killick Drain upstream of the floodgates [refer Section 6.3.3.3]). The model can also be used to identify other means of improving efficiencies within the flood mitigation scheme, such as potentially increasing the capacity of Ryans Cut, partial or complete infilling of minor, dysfunctional drains, or modifications to any other elements of the local flood mitigation scheme (such as installation of new dropboards) as postulated by landholders and local authorities.

One of the key advantages of a numerical model is the ability to change inputs and to perform ‘what if’ scenarios. Modelling can be carried out to assess conditions during major floods, nuisance floods and non-flood periods.

Agricultural landholders in the Belmore Swamp area should be consulted closely during the course of the project to help devise possible options for alternative drainage schemes. Landholders should also be consulted regarding what drains may be currently too deep and what drains are considered to be redundant within the system (or even inhibit effective management of the land).

The outcomes of the modelling study should be used to direct the long-term management program for the Killick floodgates, and as such, is likely to have an influence on how the Killick Creek estuary is managed in the future (thus its connection with this Estuary Management Plan).

Costs:

Establishment of a detailed hydrologic and hydraulic model of the Belmore Swamp area, including detailed consultation with landholders and analysis of a range of potential options for altered drainage, is likely to cost in the order of \$160,000, including necessary ground survey of swamplands and channel to define model hydraulics. Costs associated with modifying the floodplain and drainage system, as a possible outcome of the study, have not been considered.

Consistency with other Plans and Policies:

The hydrologic and hydraulic study would aim to optimise floodplain management and swampland drainage, within the context of minimising environmental impacts and accommodating future climate change (including increasing sea-levels). As such, the strategy is consistent with the objectives of the Lower Macleay River Floodplain Management Plan (refer Section 1.7) and the principles of the State Coastal Policy (Section 1.3.3).

6.3.3.3 Sed-2: Construct a block in the drain upstream of the floodgates

Rank: 18/22

Addressing Objectives: 8, 11

Description:

Once a communication framework with the upstream landholders has been established, consultation regarding potential options should be undertaken. One such potential option is the construction of a block weir in the agricultural drain upstream of the Killick Floodgates. First suggested by an upstream landholder, this option is designed to allow better control of the drainage system within Belmore Swamp so that the drains can be used more effectively in land and acid sulfate soil remediation.

The location and configuration of the proposed block weir would need to be determined in close consultation with all affected landholders. Adaptability / removability of the structure is likely to be a key design consideration. It may even be determined that a series of block weirs are required within the drainage system, which can be opened and closed, as necessary to maximise potential for land remediation. As appropriate, structures constructed within the drains could also incorporate vehicular access over the drains, which at present, is significantly limited by the bisecting nature of the existing drains.

In concert with the construction of a block in the drain, consideration should be given to providing formal vehicular access over Killick Drain. When the drain was constructed in the 1950s, no provision was made for access to the land to the western side of the drain from Loftus Road. A Crown road easement is located between lots 19 and 46 to the north of the Killick Creek floodgates (refer Figure 6-8), and may provide a suitable location for access and the proposed block weir.



Figure 6-8 Crown road access to Killick Drain

Costs:

Costs associated with implementing this strategy are very dependent on the nature and number of structures that are considered necessary by the landholders (in consultation with DNR, DPI and the CMA). An allowance of approximately \$100,000 should be made for all necessary consultation, feasibility and environmental assessments, design and construction of the structures. Given that the structure would need to be constructed within a SEPP-14 wetland, it is anticipated that the works would be deemed 'designated development' under the EP&A Act, and an EIS would need to be prepared to accompany the development application for the works.

Consistency with other Plans and Policies:

Additional structures within waterways would need to be considered carefully in terms of fish passage and migration. S.5.3 of NSW Fisheries (1999) provides policies and guidelines for construction of barriers across watercourses. In principle, NSW Fisheries (1999) discourages construction of additional barriers, particularly where fishways are not provided.

6.3.3.4 Ecol-2: Assess wetlands and existing endangered ecological communities, such as saltmarsh, and protect through LEP revision and/or SEPP-14 amendments

Rank: 19/22

Addressing Objectives: 10, 11

Description:

There are a number of SEPP-14 wetlands within and around the Killick Creek estuary, including the wetland to the immediate north of Muddy Arm (see Figure 1-4). Original mapping of the SEPP-14 wetlands was based on large scale aerial photographs, taken during the early to mid 1980s. Given that Killick Creek has continued to become more 'marinised' over the past 50 years, it is possible that the existing extents of the coastal wetland habitats is quite different to that gazetted on the maps.

Also, some estuarine habitats have recently become protected under the TSC Act 1995, being listed as Endangered Ecological Communities (including saltmarsh habitat, coastal floodplain wetlands and coastal rainforests). It is recommended that ground-truthing of all existing habitats around the Killick Creek estuary is undertaken to identify and confirm habitat structure, and determine the presence of any threatened ecological communities.

Mapped boundaries of coastal wetland and endangered ecological communities should be used to modify future landuse zoning as part of the proposed LEP review, and adopt a suitable environmental conservation zoning.

Costs:

Costs for ground-truthing and remapping of coastal / estuarine habitats would be in the order of \$40,000. There may be considerable benefit and cost-savings if this strategy is implemented in conjunction with Strategy Ecol-5 (see Section 6.3.3.6), which involves a detailed survey of flora and fauna in and around the estuary.

Consistency with other Plans and Policies:

Identification and mapping of endangered communities and sensitive estuarine habitats would be consistent with the overall objectives of DEC (NPWS) and DPI (Fisheries), and is likely to form a component of the NRCMA Catchment Action Plan (CAP).

6.3.3.5 Ecol-1: Rezone the estuary to 'Environmental Protection'

Rank: 20/22

Addressing Objectives: 10, 11

Description:

All coastal councils in NSW are required by Department of Planning (DoP) to review their LEPs before 2009. Kempsey Shire Council is currently reviewing the LEP. The forced review by DoP is designed to gain consistency across the state with respect to zoning for landuse, and the descriptions of these landuses (see Section 1.5 for further details).

At present, most of Killick Creek waterway is unzoned, while the Muddy Arm section of the estuary is zoned both rural and open space (see Figure 6-9). This strategy involves rezoning the estuary to a suitable 'environmental protection' zoning, which is consistent with other estuaries around the state, and reflects the importance of the estuary from an environmental perspective. By being zoned for environmental protection, the estuary is afforded protection from inappropriate development in the future.

Costs:

Costs associated with rezoning the Killick Creek waterway as part of the proposed LEP review would be minimal.

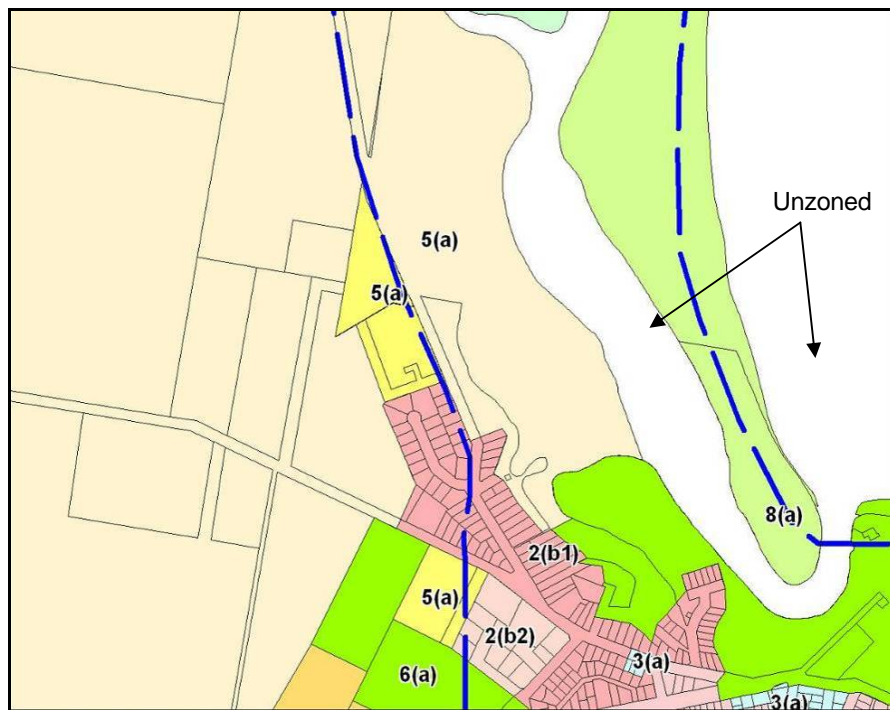

Figure 6-9 Existing landuse zonings within and around Killick Creek

Consistency with other Plans and Policies:

The draft LEP template, as developed by Department of Planning for adoption by Councils across the state, provides a 'waterway' zoning, which would be appropriate for Killick Creek.

Zoning of the waterway, particularly for environmental protection, also reinforces the value of the area, which is advocated by the Healthy Rivers Commission's investigation into Northern Rivers.

6.3.3.6 Ecol-5: Flora / fauna surveys of the waterway and the foreshore

Rank: 21/22

Addressing Objectives: 11

Description:

The Killick Creek Estuary Processes Study (MHL, 2003) concluded that there was a significant lack of information with respect to the aquatic and terrestrial ecology of the estuary. As such, it is difficult to determine the likely impacts of existing inputs and future management actions on the ecology of the estuary.

In order to fill this knowledge gap, a detailed flora and fauna survey of the estuary and adjacent terrestrial habitats is recommended. This survey should determine the ecological values and significance of the estuary as a habitat environment. Repeat surveys should then be undertaken on a periodic basis (i.e. every 5 – 10 years) to determine if there is any on-going change to the ecological environment, and if management actions associated with implementation of this Estuary Management Plan are having a net positive impact on the ecology of Killick Creek. Flora and fauna surveys should also identify the presence of weeds and pest species, so that future abatement programs can better target specific species that are present around Killick Creek.

Costs:

The costs associated with carrying out a detailed flora and fauna survey of Killick Creek and surrounding terrestrial habitats are expected to be in the order of \$70,000. Cost efficiencies can be achieved if this strategy is implemented in conjunction with Strategy Ecol-2 (see Section 6.3.3.4).

Consistency with other Plans and Policies:

As for Strategy Ecol-2 (see Section 6.3.3.4), flora and fauna mapping and condition assessment would be consistent with the overall objectives of DEC (NPWS) and DPI (Fisheries), and is likely to form a component of the NRCMA Catchment Action Plan (CAP).

6.3.3.7 WQ-5: Encourage on-site stormwater management

Rank: 22/22

Addressing Objectives: 1, 2

Description:

Whilst proposed urban development is required to implement total water management, existing urban residents of Crescent Head should also be encouraged to adopt on-site stormwater management. Options available to existing residents include installation of rainwater tanks, grass swales and on-site detention and bioretention cells. Grass swales and bio-retention would be most effective on flatter sections of topography, while rainwater tanks are recommended for steeper lands, where other measures are generally less practical. Council could encourage uptake of on-site management through subsidies, such as discounted rainwater tanks.

A targeted education program would be required to help encourage on-site stormwater management within the existing urban development of Crescent Head.

Costs:

Costs associated with implementation of this strategy are difficult to quantify, as it would depend on the nature of the subsidies offered by Council. Nonetheless, an allowance of \$50,000 has been made for accounting purposes.

Consistency with other Plans and Policies:

This strategy is consistent with the outcomes of the Kempsey Integrated Water Cycle Management Study (refer Section 1.4.17), while any resulting reduction in pollutant loadings to Killick Creek would be consistent with the objectives of the Estuary Management Policy (refer Section 1.3.2) and the goals of the Coastal Policy (refer Section 1.3.3).